

# Independent fuel-free electric VEGA

*Structure and working principle electric VEGA 1-5 kW*



INDEPENDENT fuel-free electric generator VEGA belongs to the class, "self-healing Fuelless charger for the battery, operating in pulse - jog" This is a complete and high-quality replacement wind generators, solar panels, with a major advantage: independence from wind, sun and weather.

Generator VEGA - a hybrid system that converts kinetic energy into electromagnetic and high ripple current, ie, converts the kinetic and electromagnetic energy in the high current pulses. Simultaneous multi-pole brushless generator forward rotation without gear. For the production of generators used VEGA firepower of 1 to 5 kW, which is an outer rotor, i.e. It rotates the generator body. The generator frame is fully protected from the external environment, so that dust, moisture, salt and chemicals do not affect the machine. This is an important factor, speaking about its reliability.

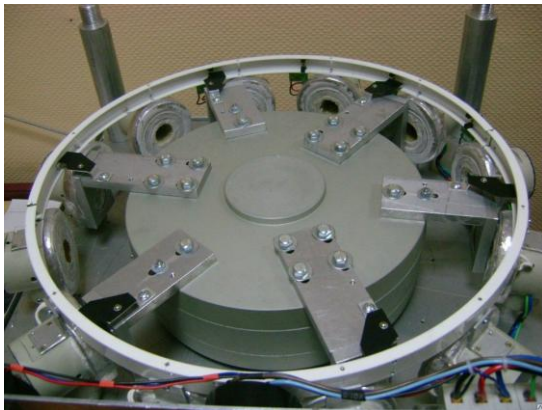

On the generator rotor on the outside diameter, fixed magnity- NdFeB, field strength, which is adjusted individually, based on the rotational speed of the generator at which develops the inertia of the flywheel movement..

REGENERATIVE SYSTEM USING ROTOR ROTATION MODULE ACCELERATOR electromagnetic coils 8 ohms. OPENING TIME is fixed at 1.8 degrees, whatever the rate of

rotation of the rotor. "SEMF" (counter electro magnetic force) USED FOR REGENERATION pulse character, the amplitude of 350 V. regeneration efficiency 300%.



Synchronous generator, reversed N-pole of the magnet to the outside provides constant rotation under the control of the jog dial accelerating effects of electromagnetic coils of special geometry.

High negative voltage peaks on the collecting coils of transmit energy in the battery to maintain a constant rotation. This is a new approach to the well-known motor Adams.

The generated three-phase alternating current generator passes to the controller, which multiplies and accumulates energy over time, and then outputs it in the form of intermittent high current pulses to the inverter charging batteries.

The principle of the creation of the controller is based on the principle of a cascade capacitor multiplier (1 to 4), the concept of the multiplier voltage was developed back in 1919 by Swiss physicist Heinrich Greynaherom. The controller is based on the multiplier converts AC or pulsating DC voltage into a high DC voltage. The controller is designed staircases capacitors and diodes improved scheme is used John Cockcroft and Ernest Walton research, for which he received the Nobel Prize in physics in 1951 year. Formation of high-frequency inductive pulse, which in combination with high inertial generator capacity, allow the battery to charge to the speed is up to ½ of the generator rated power. Mode Controller 0 to +25 degrees. Set in the room. Optionally hermetic packaging are available for a controller system for use in a wider temperature range. To the device can be connected in parallel, in series up to 8 batteries 12V-200A / h. Charging the battery takes place by high-frequency ultrashort pulses (pulse voltage reaches up to 600 V) power of 0.1-0.5A current.

Energy is generated by the synchronous generator (3 phase generator) - ONLY stimulation ROTATION high inertia rotor (BODY generator) generates the external excitation coils. The excitation energy is 100% regenerated in coils system. Connecting the consumer load through the controller VEGA does not lead to an increase in energy expended by the coils and the generator brakes NOT because energy "removed" from the generator rotating at the "idle".

### *Electricity generators "VEGA" In Polls AND ANSWERS*

1. What is the electric Adams - Vega?

**Answer:** Generator "Vega", is classified as "fuel-free self-healing chargers for rechargeable batteries, operating in pulse-jog", without fuel consumption. Generator "Vega" - a quality and complete replacement of the wind generator, solar panels. Generator "Vega" does not depend on wind and weather conditions, 24 hours a day. Generator "Vega", does not belong to the category of "perpetual motion."

**For example:** You have installed a wind generator. It generates electricity, which is stored in the battery, from which through the inverter, the power is supplied to your home. In this case, the wind is the force that spins the blades. The blades twist generator. The generator generates electricity. Electricity is stored in the battery. Then it all depends on how you will consume this electricity. You can give a greater load and select it for an hour and wait for the wind generator again it will work out, and can be used 24 hours a day and will have time to vetrogenerator its produce and accumulate. In the case of fuel-less generator "Vega", everything happens exactly the same, but do not need the mast, the wind and the blades instead are magnets and electromagnetic coils. Generator Vega just spin and generates electricity, accumulating it in the

battery. Then it all depends on how you will use this energy, or all at once or gradually 24 hours a day. The main thing to choose the right generator, according to your needs.

**Another example:** Take the charger to the battery of the car. The network acts as a source of electricity. Battery drive. In the case of fuel-less generator "Vega", a source of electricity generator stands and magnets and electromagnetic coils only twist it. Battery storage is. Then it all depends on how you will consume this electricity. Generator Vega can not work directly, without batteries.

The generator produces electricity to charge the battery, which can be connected to the inverter and to receive 220V / 50Hz, for your home.

Power generator, 1 kW to 5 kW.

**Enterprise developer Independent fuel-free electric VEGA  
marketing technical diagrams and drawings of self-assembly VEGA**

<http://npp-dpverano.pulscen.com.ua/goods/35726737->

[beztoplivny-generator-vega-ukraina-dp-verano-npp-kb-verano-ko](http://npp-dpverano.pulscen.com.ua/goods/35726737-beztoplivny-generator-vega-ukraina-dp-verano-npp-kb-verano-ko)

\*\*\*\*\*

Scheme manufacturer did not provide free access. But this unit is repeated craftsmen from Ukraine who shared scheme.

These materials below:

*.....because the city is forbidden to put windmills needed a idea how to promote a generator without using the mast and blades. We decided to use the coils and magnets. Generator Odessites could unleash. Now the generator produces 500 volts the break between the phases. But he is limited in power - only one kilowatt. Buy in Odessites more powerful generators were not - it's too expensive. We are working on increasing the available generator power, there are some ideas.*

*Then the idea of the same principle to produce a universal rotator to rotate as the generators and engines (especially asynchronous, which easily convert to the generator). They collected installation, which you saw in the photo and video. Installed coils 240, 120 domestic, 120 outdoor and 30 drives across five magnets. The control circuit coils exact same as in Odessa generator.*

*Already we have a result - 1680 rpm on the shaft 24 volt supply 20 amps operating current, torque strength of about 100 kg on the shaft.*

*If the twist is only the internal coils - one on each of the outer recess to 7 volts. If the external - to every one internal 2.5 V recess.*

*Due to the large inertia (particularly with flywheel) easily passes on samozapitku though from outside, at least from the inner coils. Connects via the vehicle's generator 4.2 kW belt loaded load of 3.4 kW - easy to pull. Who invent connection via the clutch directly onto the shaft.*

*At a load of 3.4 kW generator consumes about 500 watts. Now we remake flywheel. It must be at least 3R-range drive. Attached is a little more material. For those who chant, an important factor: the diameter of the neodymium magnets is approximately equal to the diameter of the outer coil, the distance between the disc with magnets and coils as small as possible.*

*That inscription is not true. Coils should be done of the existing magnets is based on the internal 12, external 24 volt. Diameter of the outer coil should be approximately equal to the diameter of the magnet.*

So, too, tried on small magnets - a bad result.

Yes, here the principle of pull - push. But the "attraction" is used for self-generation, and "jolt" to rotate.

On one disc, two photocell TCST1103.

The round disk opposite the magnets of each magnet in the circumferential lobe has up to 3 cm. The photocells are arranged in such a way that the petal covers the photocell when the magnet 1-2 mm pass coil center. Fires photocell control board. It is on the 555 chip. The signal from the chip is supplied to transistor switches which feed the coil. A transistor switch controls the three coils on one side and three coil located opposite on the other side. Coils under 120 degrees. Do not forget to change the polarity opposite coils on the beginning-end, otherwise it will not make a start, and will stick.

1 - 12 are coils on both sides of the disc. At points 2, 4, 6, 8, 10, magnets 12 are arranged at the edges and which overlap the pitch photocells.

Coils frameless, strapped thread and wrapped with tape. We import diodes Schottky but fit.

All magnets operate on the repulsion of the coil

We disk diameter of 400 mm with the magnets. However, during testing we observed that 500 mm would be better. We are observing the effect of the coil on the coil standing next because of the distance proximity. By increasing the diameter of the disc with magnets immediately to increase the distance between the coils.

We started with 4 finished 2 photocells. Preparing the final scheme and the size of all the elements, be sure to expose.

The dimensions will depend on the power of your spinner. ".....

### Мотор-Генератор Памяти Адамса

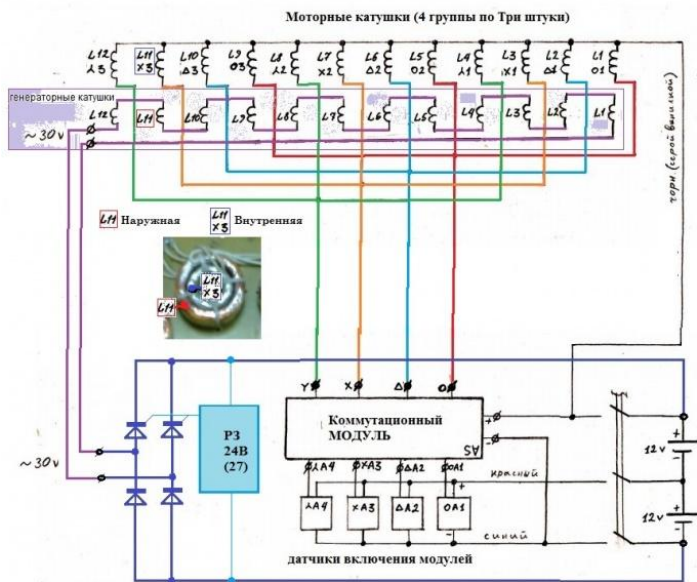

### Синхронный генератор вертикального типа

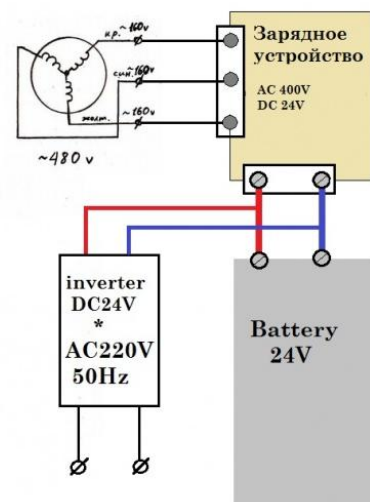



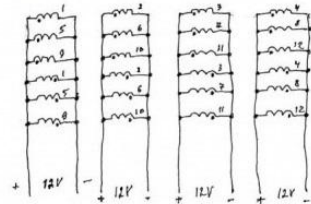
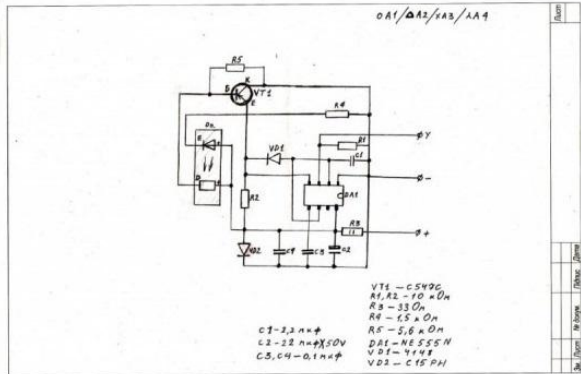
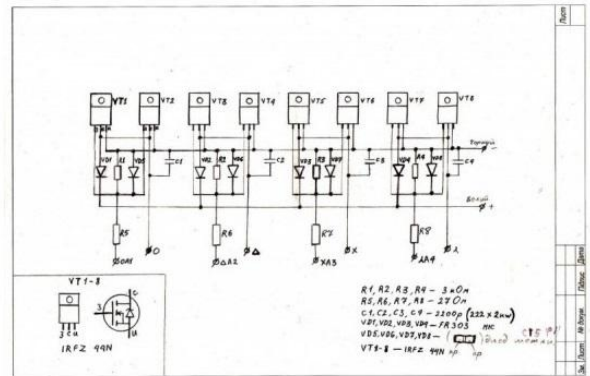
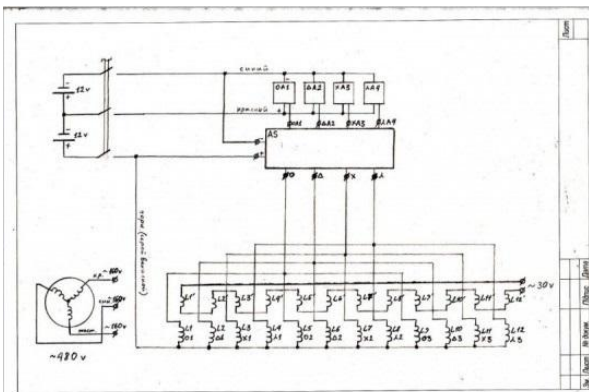

1-12 - номера катушек  
 • - начало катушек

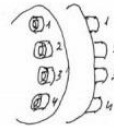

Диск с монтажем

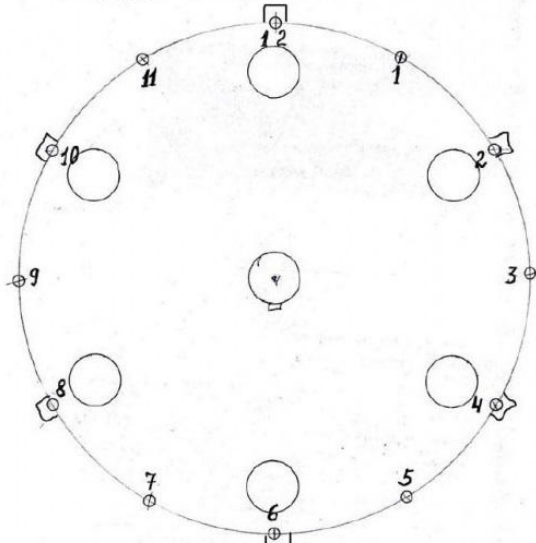

Толщина диска 10 мм  
 в диаметре 30x10 мм 24 мм отрез.  
 С двух сторон два листа по 1 мм  
 алюминийевыми заклепками.

КАТУШКИ

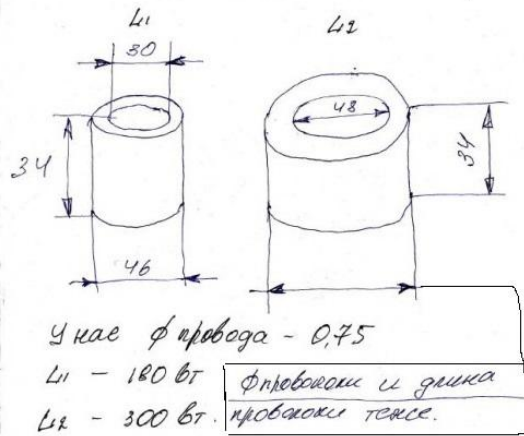

У нас  $\phi$  провода - 0,75

L1 - 180 Вт Флюоролак и длина  
 L2 - 300 Вт проводами темсе.

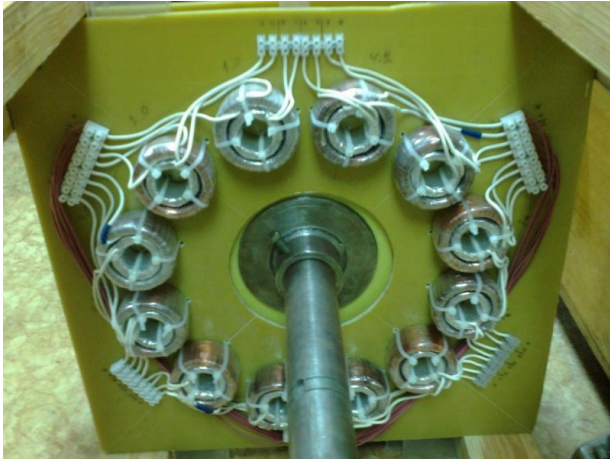

Reference to a video where the authors tested during operation

[https://www.youtube.com/watch?v=Q5g9VOY\\_EFE](https://www.youtube.com/watch?v=Q5g9VOY_EFE)